

A Guide to Video Mesh Networks

April 2008

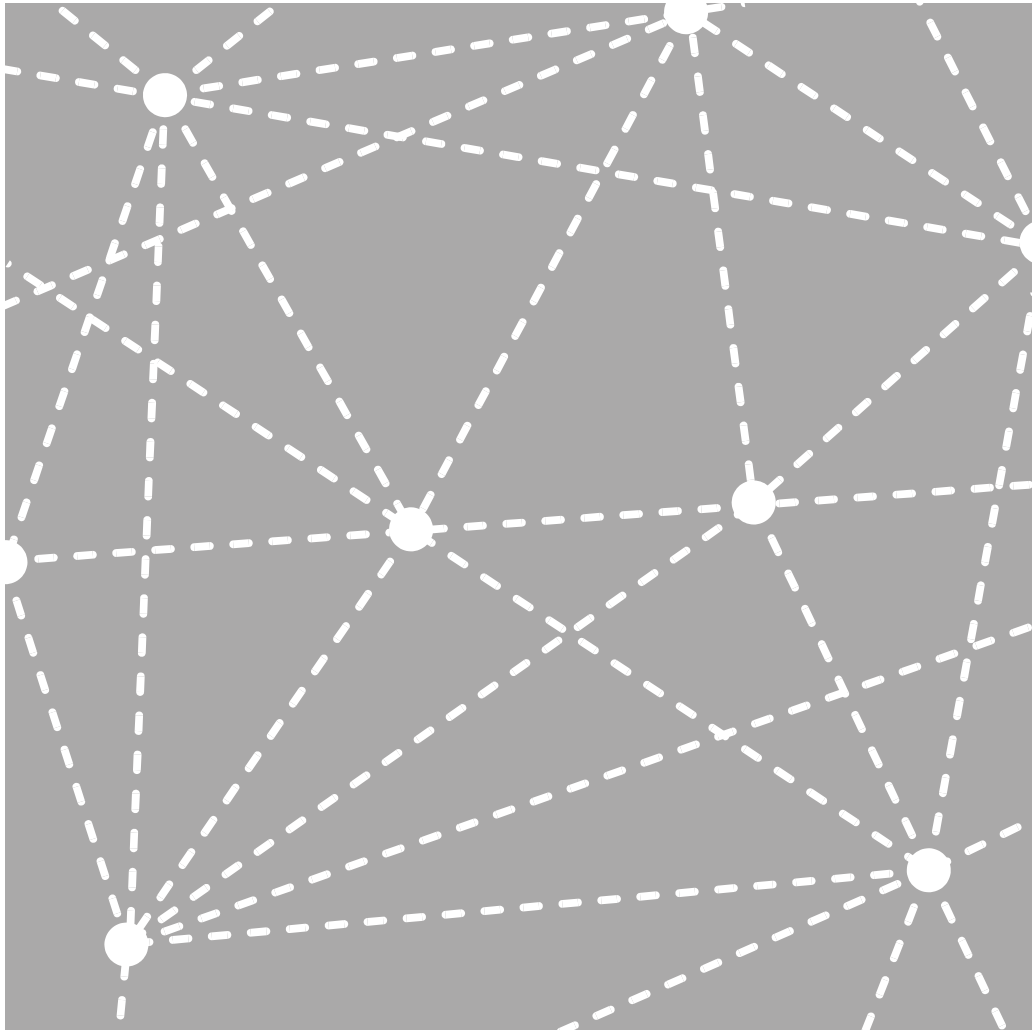

Table of Contents

Introduction.....	3
Cameras & Recorders for Video Surveillance	5
Video Displays.....	5
Digital Video Servers	5
Understanding Digital Video Network Requirements	6
Video Resolution	6
Video Pixel Representation.....	7
Video Frame Rate.....	7
Video Compression.....	7
Calculating Storage Requirements.....	9
Implementing a HotPort Wireless Mesh	11
Conclusion	14
Glossary	15

Executive Overview

This White Paper provides an overview of the current state of video surveillance technology.

Briefly, this White Paper will:

- explain the evolution of digital network cameras, also known as IP cameras.
- discuss bandwidth issues.
- Provide a overview of the installation process.

Revision 20080416-1b. The contents of this document are subject to change without notice. Please refer to the FireTide web site, www.firetide.com, for current versions. © 2005-2008 FireTide, Inc. All rights reserved. FireTide, the FireTide logo, HotView, and Wireless Instant Networks are trademarks of FireTide, Inc.

Introduction

Traditional video monitoring and surveillance applications employ analog CCTV (closed-circuit television) cameras that are wired via coaxial cabling to a centralized monitoring and recording facility. This arrangement, dating back to the 1960s, works well enough today within and around a building, and even in some campus environments, despite the high cost of cabling.

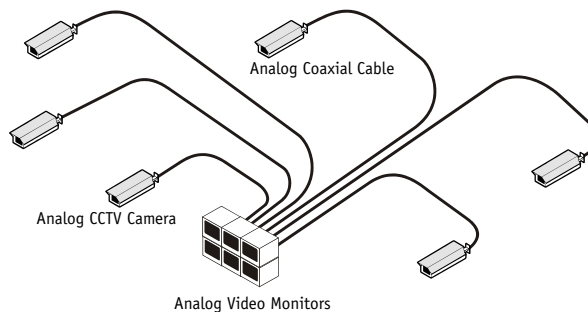

Analog CCTV (Closed Circuit Television) System with Coaxial Cabling

The advent of solid-state cameras in the 1980s, using CCD (charge-coupled device) image sensors, significantly increased the use of video surveillance cameras by making them both smaller and cheaper. Some cameras included an RF transmitter to eliminate the cable. However, image quality was poor, due to the constraints of the available analog video and radio technology.

Fully digital systems became cost-effective in the late 1990s. Digitized images combined with modern video compression technologies, such as MPEG, make it easy to transmit high-quality images over ordinary networks, including T1 (1.5 Mbps) and Ethernet (typically 10 to 100 Mbps).

Digital technology has also made digital recording and storage easy and cheap, thus obsoleting old tape-based systems. Last but not least, digital technology has made every computer a video display device, so there is no longer a need for separate video monitors.

The universal deployment of Internet technology, including IP, the Internet Protocol, has further simplified deployments. Most digital cameras are IP-compliant, and many will stream video directly to a browser window on any PC.

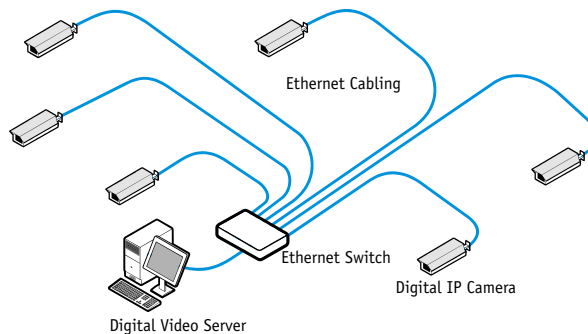

Digital IP Camera and Digital Video Server (DVS) on a Wired Ethernet

Another new networking technology delivers an equal advance in video surveillance applications: the wireless mesh network. The HotPort™ mesh network is the third generation of mesh networking products from FireTide. The HotPort system is a multi-service mesh network that enables standard Ethernet devices, including IP video cameras, to connect securely via the wireless mesh network as if connected to an Ethernet switch.

Designed for maximum performance, scalability, and ease-of-use, the HotPort mesh network operates in indoor and outdoor environments in either the 2.4, 4.9 or 5 GHz spectrum for optimum performance and minimal radio interference. With its self-healing capabilities and high sustained throughput, a HotPort mesh network is very reliable and readily satisfies the security and performance demands of video monitoring and surveillance applications.

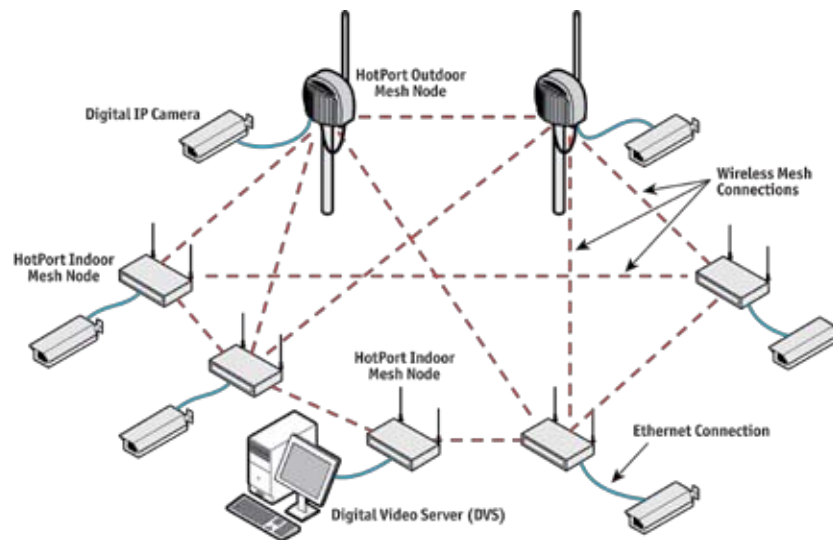

Digital IP Cameras and Digital Video Server (DVS) on a Wireless Mesh Network

By eliminating the Ethernet cabling, cameras can be placed virtually anywhere with a mesh network infrastructure. The compromises of the past (especially neglecting those locations that were impractical or impossible to wire before) can be remedied. The combination of digital cameras and a wireless mesh network is now regularly used to supplement existing analog CCTV systems. And an increasing number of companies are finding the advantages of digital video so compelling that they are replacing legacy analog CCTV infrastructures entirely.

Cameras & Recorders for Video Surveillance

Old-style video surveillance systems often failed to deliver quality images. The limitations of camera, cabling, and recording technology required numerous compromises that resulted in poor picture quality.

Today's systems require few, if any, such compromises. Modern solid-state cameras are smaller than a pack of playing cards, yet deliver broadcast-quality video. Some models can deliver HDTV-quality video. Improvements in video compression technology make it possible to deliver these images at relatively low data rates - only a few megabits per second.

The popularity of consumer digital still cameras has increased the cost and reduced the price of high-resolution imaging chips. Several security-camera vendors offer cameras based on these chips, with resolutions of 2 to 8 Mpixels. While frame rates are lower, these camera offer unparalleled ability to read license plates and other details even at great distances.

A number of vendors offer camera systems designed for surveillance. These usually include an Ethernet interface, and some model offer pan-tilt-zoom (PTZ) capability. Models optimized for very-low-light applications are also available.

Because Firetide's mesh technology works like an Ethernet switch, you can connect any type of Ethernet-capable camera to it. If you already have analog cameras, you can purchase analog-to-digital converters which will connect to any Ethernet system. This flexibility lets you mix and match cameras to suit your needs.

Video Displays

Old-style analog video systems required dedicated TV monitors. Modern digital systems can be displayed on such monitors, but it is easier and less expensive in most cases to use a PC or laptop. This give view-from-anywhere flexibility and provides a platform for camera control as well as viewing.

Digital Video Servers

The destination for video is usually a central monitoring facility. The facility includes one or more real-time displays, typically a standard PC, and a digital video server (DVS) for storing and retrieving the many individual streams. A DVS is a specialized PC, equipped with a large number of large hard disks on which video is stored digitally. It replaces the old-style video-tape recorder. Among its many advantages is reduced labor costs. You no longer need to pay someone to continually change tapes.

A single DVS system is typically capable of supporting up to 32 cameras, and multiple DVSs can be deployed in either a centralized or distributed fashion. DVS contents can be archived to other media, but it is increasingly common to simply keep adding disk drives.

Understanding Digital Video Network Requirements

Connecting digital cameras via wired Ethernet LANs is now common practice. An Ethernet network can readily meet and exceed any reasonable requirement for video monitoring and surveillance. An Ethernet network based on wireless technology can do the same, if the wireless design is correctly engineered. For this reason, it is important to understand what is required of a wireless network to adequately support video traffic.

In a video application, the network must be capable of carrying the aggregate throughput required to deliver the packetized video streams being generated by all of the cameras. Assuring adequate packet throughput performance can require a substantial amount of bandwidth to accommodate the total, end-to-end traffic load.

While one thinks of traffic in a video network as being all 'upstream', that is, from the cameras to the screens, it's actually two-way. PTZ cameras require two-way traffic, of course, in order to receive operator commands. The network protocols themselves are also two-way. Cameras are typically viewed using a browser-based interface; such connections are always two-way, even if the bulk of the flow is upstream.

Video Resolution

Over the years, the computer and television industries have developed numerous resolution standards and acronyms. It's beyond the scope of this white paper to cover all these standards, but because it's a key parameter in selecting surveillance cameras, we will look at some of the more common standards.

In digital video monitoring and surveillance applications, the cameras are based on standard video camera technology. Most cameras in use today offer the same resolution as standard television. HD (high-definition) cameras, offering the same resolution as HD TV, are also available.

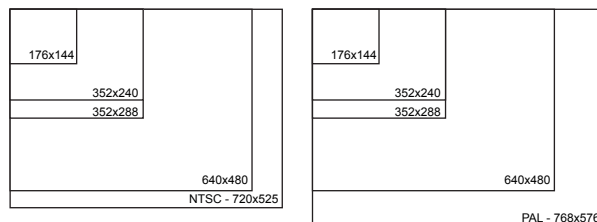

Comparison of Video Image Sizes

The equivalent digital resolution of a standard television signal has been defined in more than one way. The difference arises in part because standard television 'overscans' the picture. That is, unlike a computer monitor, a television image extends beyond the visible edge of the screen. In other words, some resolution is lost. The 'official' size of a TV image in use is 720 pixels in width and 525 lines; however, only 480 lines are displayed. PAL, used in Europe and some other countries, is 768 by 576. This resolution is known officially as ITU-R BT.601, but is commonly referred to by its old name, CCIR-601.

Some early video systems, such as those used for video conferencing, could not support the standard television resolution. Lower-resolution standards were developed. These include CIF (pronounced 'siff'), the Common Intermediate Format, with a resolution of 352 by 288. Note that this is approximately one-half the size of standard television; thus it requires only one-quarter of the pixels. Extremely low-resolution systems use QCIF, halved again to 176 by 144.

Another, similar standard is called SIF. Pronounced the same as CIF, it is 352 by 240.

First-generation VGA computer displays are 640 by 480. Because 640 is only a little smaller than 720, and because the practice of overscan meant that all 720 pixels didn't get displayed anyway, it has become common practice to trim a television image to 640 by 480 for use on typical computer monitors. Thus, many cameras designed for surveillance work will generate a 640 by 480 image.

HDTV images are 1920 by 1080 maximum, but several camera vendors have introduced cameras with even higher resolutions. One vendor offers cameras with 2500 x 1900 resolution.

Video Pixel Representation

Monitors display pixels using a combination of Red, Green, and Blue (RGB). Most modern systems use a 8-bit value for each pixel; thus 24 bits or 3 bytes are required.

This high degree of resolution is excessive. The human eye does not perceive color as sharply as it does overall brightness and detail. Thus, it is possible to reduce the amount of color in an image without a perceptible loss of quality. There are numerous schemes for this. A full analysis of these techniques is beyond the scope of this white paper. It's sufficient to note that in most cases a pixel can be represented with only 1.5 to 2 bytes, depending on the technique used.

Video Frame Rate

In the US NTSC system, television is recorded at 30 frames per second. Under PAL, it is recorded at 25 frames per second.

Some early video surveillance systems reduced the frame rate in order to reduce transmission requirements and video storage requirements. Frame rates were as slow as two frames per second. Because transmission and storage has improved dramatically, this is no longer necessary. While 30 frames per second is considered "full-motion", in most cases any frame rate greater than 20 frames per second appear life-like to the average viewer, and frame rates as low as 15 frames per second provide a reasonable simulation of motion.

Video Compression

A standard television image, consisting of 720 by 480 pixels, at 30 frames per second, represents a pixel rate of 720x480x30, or 10,368,000 pixels per second. For a full-color image, this represents a data rate of over 240 megabits per second, a rate that would tax even a fast Ethernet system.

Happily, video compression technology dramatically reduces the required data rates. Using modern video compression techniques (called codecs, a contraction of coder-decoder) such as MPEG-2, MPEG-4, and others, high quality video, equivalent to a DVD, can be transmitted at

rates as low as 10 Mbps. These codecs are well-proven; they are used in the broadcast and DVD industries by the millions. Near-broadcast quality video can be transmitted at rates below 1 Mbps. Low-quality video can be sent at rates around 100 Kbps, but this is not usually useful for surveillance activities.

There is another compression standard popular in surveillance applications, called Motion JPEG, or MJPEG. JPEG is a compression standard for use on still pictures, for example in a typical digital snapshot camera. Motion JPEG treats video as a series of still images. Each image is compressed individually; the sequence of compressed images is then transmitted with no further compression. While not as efficient as the MPEG standards, it does deliver sharper 'freeze-frame' images; useful in evidentiary applications.

Most vendors offer a range of choices for video compression. However, you should measure cameras in real-world situations before finalizing a network design. Data rates vary with the amount of motion in a scene, and real-world situations result in rates higher than test conditions.

A Note on Frame Rate and Video Compression

The concept of frame rate becomes more complex with modern video compression techniques. MPEG-2, MPEG4, and other techniques (except MJPEG) use interframe compression. In this technique, rather than transmitting a series of frames, the camera sends a update only for that portion of the image which is changing. Since most of the time, most of the image is not moving, this results in a significant reduction in bit rate. It does, however, mean that the entire image is NOT updating at the specified frame rate; only the active regions are.

Calculating Digital Video Network Bandwidth Requirements

The following equation can be used to determine bandwidth requirements for a single camera:

$$\text{Raw Bandwidth} = \text{Width} \times \text{Height} \times \text{Pixel Depth} \times \text{FPS}$$

$$\text{Average bandwidth} = \text{Raw Bandwidth} \times \text{Compression Factor}$$

Where...

Mbps = Megabits per second (1 Mbps = 1,048,576 bits per second)

Width = frame width in pixels

Height = frame height in pixels

Pixel Depth = average number of bits per pixel

FPS = frames rate in frames per second

Compression Factor = the ratio of the compressed version to the original.

Example

A major security camera vendor offers a model which delivers color VGA video at 15 FPS.

- 640 x 480 pixels equals 307,200 pixels
- 307,200 pixels at a pixel depth of 12 bits per pixel (1.5 bytes) equals 3,686,400
- 3,686,400 at 15 fps equals 55,296,000 bps, or 55 Mbps.
- 30:1 compression ratio yields 1.8 Mbps

This will result in a near-broadcast quality image reproduction. Note however that not all camera codecs can achieve 30:1 compression. Calculated bandwidths are useful for preliminary system design, but cameras vary widely. Furthermore, newer and more efficient codecs are being developed and introduced. Obtain and measure your chosen camera before finalizing your design.

Calculating Storage Requirements

Modern surveillance systems use disk drives rather than tape for storage. It's more reliable, makes video available online for viewing, and avoid the need to pay humans to change tapes.

Storage requirements are driven by several factors:

- Video data rate
- Number of cameras
- Number of days of storage

Because modern codecs can deliver good-quality video at data rates of 1 to 2 Mbps, a day's worth of storage requires only about 10 to 20 gigabytes of disk. With disk sizes of 500 GB to 1 TB, multiple days worth of video from multiple cameras can be easily and economically stored.

The mathematics is straightforward. Disk capacity required per hour per camera is simply the camera's video data rate (in megabits per second) divided by 8 (to convert to mega Bytes per second, and multiplied by 3600 to convert to megabytes per hour. Thus, a camera delivering video at 2 Mbps requires $(2/8) * 3600 = 900$ megabytes per hour, or about 22 GB per day.

If even greater storage is required, the video can be further compressed, a process known as transcoding. Transcoding uses a more powerful compression algorithm to reduce size, and will reduce quality slightly. In some cases the frame rate may be reduced as well. Today's best codecs can record surprisingly good full-motion video at data rates of only a few hundred Kbps; with a reduced frame rate this can be reduced to less than 100 Kbps.

Planning for Growth

Modern IP video systems with digital storage offer another advantage: storage is easy to add. Storage is usually implemented via a so-called NAS - Network Attached Storage. A NAS has an Ethernet connection and room for a large number of disks. NAS units can be added virtually without limit as storage requirements grow. This simplifies planning.

Video Surveillance with a Firetide Wireless Mesh Network

A Firetide network satisfies the requirements for video surveillance applications.

Performance/Scalability—Mesh topologies are known for their high aggregate throughput based on multiple concurrent traffic flows, and excellent scalability. A HotPort mesh can cover large areas, in excess of 25 square miles (64 square kilometers). Traffic can be prioritized for maximum throughput and minimum latency. Other features that enhance performance and scalability include dual radios, multiple Network Gateway Interfaces and support for Virtual LANs.

Dependability—A HotPort mesh can be designed to eliminate single points of failure. The self-healing nature of the mesh automatically routes traffic around any node that becomes congested, experiences interference or obstructions, or fails to operate. For example, installing two HotPort nodes at the “center” of the mesh (where the DVS is located) provides automatic failover without a separate (and costly) load-balancing switch. The result is a resilient network.

Security—Security is assured in a HotPort mesh through a number of provisions. Only HotPort nodes are permitted to participate in the mesh network, to prevent outside tampering. Traffic filtering and VLAN provisions block all unauthorized traffic from entering the mesh. Strong encryption—up to 256 bit AES—protects the integrity and privacy of traffic from end to end.

Indoors and Outdoors—All HotPort equipment is appropriately ruggedized. The indoor unit is plenum-rated. The outdoor unit is fully weatherized in a cast aluminum enclosure. Outdoor HotPort units offer Power over Ethernet (IEEE 802.3af) to power attached cameras.

Ease of Use—A HotPort mesh is an Ethernet switch, and fundamentally works like wired Ethernet switches. Thus it fits into standard IT network topologies. HotPort meshes can do more. Because they auto-discover in real-time, cameras can be portable or mobile. HotView Pro™ mesh management software provides highly intuitive control of the entire mesh and individual mesh nodes.

Affordability—A HotPort mesh is the least expensive wireless option available, both in terms of initial expense and operating expense. Equipment cost is moderate and scales linearly. The mesh easily adapts to changing needs, providing solid investment protection.

Mobility – A HotPort mesh network supports real-time redeployment of assets, which is particularly valuable for police and fire departments, and in other tactical situations. The self-healing mesh automatically adds new nodes as they move within and throughout the range of other nodes. Nodes are small enough and light enough to mount in vehicles. These nodes can be equipped with either cameras or PCs, or both, if desired.

Implementing a HotPort Wireless Mesh

FireTide's HotPort mesh network is designed for maximum performance and reliability in a variety of applications. The HotPort mesh is scalable and operates in indoor and outdoor environments in either the 2.4 GHz, 4.9 GHz, or 5 GHz spectrum. With its self-healing capabilities, automatic traffic management, and per-channel throughput over 25 Mbps, a HotPort mesh readily satisfies the demands of high-bandwidth, low latency applications, including video surveillance.

The key advantage of a FireTide wireless mesh network is its ability to provide Ethernet connectivity anywhere, without wires. This makes the mesh ideal for locations where network cabling is too expensive to install, such as historic buildings, outdoor locations, and temporary venues.

To all connected systems and equipment, the entire HotPort mesh network functions as an Ethernet switch. For this reason, any Ethernet device can operate over the mesh without any additional setup, drivers or special software. Any device—IP camera, DVS, server, PC, or whatever—simply connects to one of the Ethernet ports on a HotPort mesh node exactly as it would to a physical Ethernet switch. A FireTide mesh is a layer-2 mesh; it is independent of IP, the layer-3 protocol. Thus it is fully compatible with existing network systems and does not require any special IP configurations, unlike some wireless products.

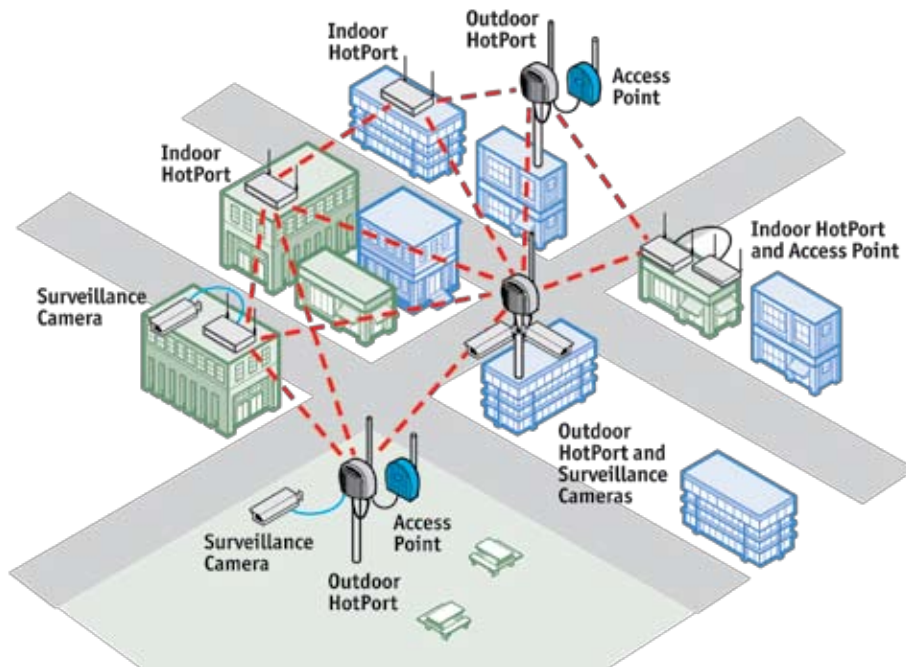

FireTide HotPort Wireless Mesh Network

When planning your mesh, consider two capabilities unique to FireTide's mesh technology: movable cameras and movable viewing monitors.

A video camera and a FireTide node can be used as a portable assembly and placed anywhere

How Fast Is That Network Anyway?

The actual data transmission capacity of an Ethernet network is not constant, but depends on the number of devices using the network and the size of data packets being sent. Ethernet is based on a protocol called CSMA-CD: Carrier-Sense Multiple Access with Collision Detect. This system requires each device to listen before attempting to transmit, and to back off (stop transmitting and wait for a short period) if it detects a collision. The result of this is that the actual throughput will be less than the raw bit rate. The amount less will depend on the number of collisions. Furthermore, different devices send different sizes of Ethernet frames, but the time between frames is more-or-less constant. Thus, when shorter frames are sent, the actual throughput also drops due to the relative increase in overhead.

This might seem like an erratic way to transmit data, but it has been proven in literally millions of installations. Video data is more time-critical than conventional data (e.g. email), so to insure timely arrival of video data, an Ethernet system should not be run at its maximum capacity. The higher number of collisions that would result will delay data arrival, and can result in jerky video.

Wireless Ethernet adds another factor. All varieties of 802.11 (a, b, and g) support multiple data rates and automatic rate switching. For example, 802.11 a and g can transmit at raw data rates as fast as 54 Mbps under optimum conditions. But 802.11a, for example, is actually transmitting at only 250,000 symbols per second. It uses a very complex mathematical technique to pack as many as 216 bits into each symbol, yielding 54 Mbps throughput. If signal conditions are less than optimum, the link automatically shifts to a less-complex technique with fewer bits per symbol. Optimum conditions don't always occur in the real world, and it's not always cost-effective to engineer an installation to deliver 54 Mbps. Thus, most mesh design engineers assume an effective speed of 36 or 24 Mbps. This avoids the time lost when the link automatically switches back and forth between speeds.

Furthermore, each radio link is half-duplex; that is, at any one instant it can transmit or receive, but not both. Since real-world applications require two-way traffic, some of the available link capacity must be allocated to the other direction.

Where does this leave the video mesh designer? Each radio has a theoretical maximum bit rate of 54 Mbps, but may well shift down to 36 Mbps under real-world conditions of noise and interference. Ethernet overhead reduces the effective data rate due to interframe time and collision overhead. The wireless mesh itself uses a small amount of bandwidth to maintain and report link conditions and statistics. Under laboratory conditions, total throughput of about 70 Mbps can be obtained. Each radio link has a maximum throughput of about 35 Mbps. Ethernet frames are not split across radios, however, so any one camera is using one radio link. In order to avoid excessive conditions and the possibility of jerky video, FireTide mesh design engineers assume 20 to 25 Mbps per radio link for video applications.

within the overall mesh, in order to provide video surveillance. Some users develop camera ‘blinds’ so that surveillance can be conducted covertly. In addition, camera-node pairs can be placed on busses or other moving vehicles to provide surveillance.

In either case, the mesh should be engineering to provide sufficient reserve bandwidth for these applications.

Because digital surveillance video can be viewed from any laptop, it is increasingly common to design system which permit police in patrol cars to view surveillance image via an in-car laptop. Again, provision should be made in overall network engineering to support this.

A detailed tutorial on planning a mesh network can be found in Firetide’s “Designing and Deploying a Firetide Mesh Network”, available at www.firetide.com. This 36-page document explains RF technology and the importance of a good site survey. It also addresses network planning and provides a step-by-step guide to planning and deployment.

The planning and deployment process can be summarized in these four steps:

Step 1—Analyze Your Needs

With a plan of the site in hand, consider all the locations where you will want cameras. In addition, decide whether you want the mesh to carry data or VoIP traffic. Estimate the total bandwidth required. Define the points where the mesh will connect with the wired network.

Step 2—Conduct a Site Survey

A Site Survey is a detailed, on-site analysis of the physical site, involving analysis of the RF characteristics of each potential node location, as well as an assessment of installation issues.

No aspect of system design is more important than a Site Survey. Only by visiting the site can you discover potential view-blocks for camera locations, possible RF issues, and other real-world factors.

Step 3—Plan Your Deployment

Using the data from the Site Survey, develop a detailed plan of where the nodes will be located and where they will connect to the wired infrastructure. A complete Bill of Materials, including antennas and mounting equipment, will be created as a result of this step.

Step 4—Deploy the Mesh

Configure your nodes, then install and test, building out as you go.

Some Deployment Tips

- If using Power over Ethernet, be sure that the camera selected supports the IEEE 802.3af industry standard. Some cameras utilize a proprietary power scheme requiring the vendor’s own power source.
- For very large-scale deployments, consider using multiple mesh networks (with different spectrum and/or channel assignments) to segment traffic for broader coverage and enhanced performance.

Conclusion

Semiconductor technology and Moore's Law have resulted in small but sophisticated digital cameras, capable of delivering high-quality video over Ethernet connections. Ever-increasing semiconductor performance has also made sophisticated network radios cost-effective. Combining the two creates a wireless mesh system fully capable of delivering

Wireless mesh technology works well for an increasing number of networking applications, and advances in digital cameras and wireless technologies now enable the use of wireless networks for video monitoring and surveillance. Uniquely, FireTide offers wireless mesh that functions just like an Ethernet switch, and is compatible with all IP routing systems.

To learn more about how your organization can benefit from the many advantages of mesh networking today, visit FireTide on the Web at www.firetide.com. There you will find additional information on mesh networking in general, and greater detail about the many advanced features in a HotPort High Performance Mesh network.

Glossary

These terms are useful to an understanding of wireless mesh technology in general and Firetide products in particular. Readers interested in a complete reference on video technology may wish to refer to **Video Demystified**, by Keith Jack.

- **802.11** - a family of protocols developed under IEEE guidelines for sending Ethernet packets over radio links. 802.11a, 802.11b, and 802.11g are currently the most widely used.
- **Bandwidth damping** - a speed-limiting effect which can occur in half-duplex networks.
- **dB**, or **decibel** - the commonly-used measure of power in RF systems.
- **CIF** - Common Interchange Format, one of a number of semi-standard video resolutions. It refers to an image that is 352 by 288.
- **Codec** - a device or software program that compresses or decompresses material (video) to reduce bandwidth and storage requirements. The term is a contraction of coder-decoder.
- **Ethernet Direct** - a wired connection within one mesh. An **Ethernet direct** connection is visible to the mesh routing algorithm, which considers its capacity and speed when routing packets within a mesh. Thus, **Ethernet Direct** links increase the capacity of the mesh in which they are contained.
- **Fresnel Zone** - the area surrounding an RF signal that must remain largely free of interfering objects.
- **Full-duplex** - some radio systems support simultaneous transmission and reception.
- **Gateway Group** - a collection of nodes configured to offer multiple egress points from the mesh. When a **Gateway Group** is used, it is usually also the **Head Node**, but this is not required.
- **Half-duplex** - many radio systems can either transmit or receive, but cannot do both at the same time. Thus in a group of nodes all within radio range of each other, at any given time only one node can be transmitting.
- **Head Node** - the node on the mesh which is logically closest to the NMS. Typically this is the node which is plugged into the enterprise backbone, and from there to the NMS system.
- **Integrated AP** - A Firetide HotPoint Access Point that is connected to a Firetide mesh node.
- **Interoperability** - in the Firetide context, use of Series 6000 nodes and Series 3000 nodes in the same mesh.
- **Link** - a connection between two nodes within a single mesh. Also known as a path. Links are generally wireless RF connections, but can be wired connections in some cases. (See **Ethernet Direct**.) The key point is that the connection is between two nodes within the same mesh; that is, within the same mesh-routing domain.
- **Mesh Bridge** - a wired connection between two distinct meshes. The meshes can be near each other, or even physically overlapping if they are logically isolated. They can also be arbitrarily far apart. Because a **Mesh Bridge** connection is between two meshes, it is not part of any mesh-routing algorithm.

- **Mobile node** - a Firetide mesh node installed in a vehicle or any other place where it moves relative to the other nodes.
- **Multipath** - the condition where a radio receiver receives two versions of the same signal, because one signal took a more direct path and the other signal a reflected path.
- **Network Management System (NMS)** - another name for HotView or HotView Pro, the system for configuring and monitoring network behavior. Note that the NMS is NOT required for network operation; only for initial configuration.
- **Node** - one of the elements of a mesh. It has one or more radios, and a CPU which implements the packet-switching algorithm. Nodes also offer wired-Ethernet ports as entry points to the wireless mesh.
- **QoS/Class of Service** - mechanism used to insure that time-critical traffic (e.g. VoIP) gets delivered promptly.
- **RGB** - Red/Green/Blue, the three colors used by CRT and LCD displays to represent images. Video in RGB format is directly displayable on a monitor, but RGB is an inefficient way to transport video information.
- **Roaming** - the ability to support 802.11 clients as they move from access point to access point.
- **SIF** - Another video resolution semi-standard. SIF is 352 by 240.
- **Standalone AP** - A Firetide HotPoint Access Point that is connected directly to the wired enterprise LAN.
- **Third-party AP** - an AP not made by Firetide. Firetide supports third-party APs, as well as other Ethernet-compatible devices.
- **VGA** - while commonly used to refer to almost any modern type of computer monitor, it specifically refers to the resolution of the early, first generation displays of the late 1980s. This resolution is 640 by 480. Higher-resolution displays each have their own acronym, for example SVGA refers to an 800x600 resolution.
- **VLAN** - a dedicated virtual Ethernet switch. Ethernet devices assigned to one VLAN are isolated from devices assigned to another VLAN. This is often used to provide security, and in combination with QoS, to provide traffic prioritization.
- **YCbCr** - a method of representing color. The Y represents overall luminance (brightness); the Cb and Cr terms define the tint, as a difference from the overall luminance.
- **YUV** - See YCbCr. YUV is not strictly identical to YCbCr, but the terms are often used interchangeably.

Notes



Firetide, Inc
16795 Lark Avenue, Suite 200
Los Gatos CA 95032 USA
+1 408 399 7771 phone
+1 408 399 7756 fax
info@firetide.com
www.firetide.com